

**I & S**  
**Brothers** Engineering Co.

**NP**  
**SAVUNMA**

Prof.Dr. Ahmet Taner Kışlalı Mah. 2883 Sok. Uyum Akın Sit. No:8 Çankaya

Ankara/TURKEY

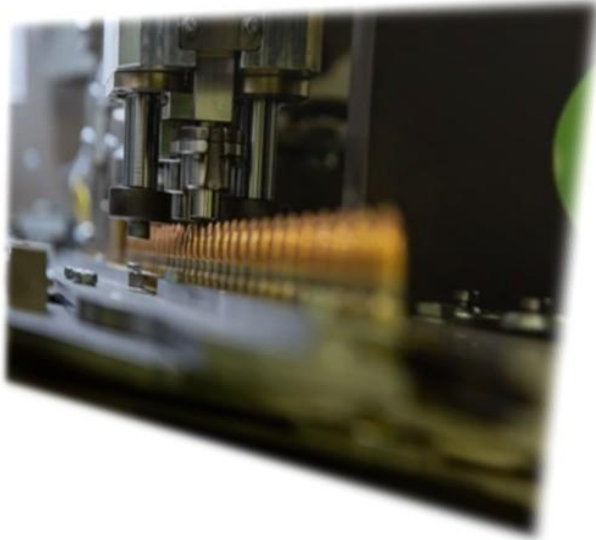

**NP**  
**SAVUNMA**

**I & S**  
**Brothers**

**Engineering Co.**

## About Us

I&SB designs and produces machineries for the manufacturers of small arm munitions, artillery rockets, and bulk explosives. I&SB also continues to work with specialized manufacturers in the fields of Defense Industry, which are located at America, Europe, and Asia, and marketing the products of these manufacturers to the customer portfolio and defense ministries around the world.

I&SB is committed to production of machineries for the production facilities of weapons, land-based platforms, ammunition used by these systems and bulk explosives in the best possible manner of commercial cooperation.

I&SB is currently has production lines for the machineries of small arm ammunitions, artillery rocket systems, mortar systems etc. in Turkey and some european countries.

I&SB was founded in 2020 in Ankara as a new company with highly experienced personnel from different countries such as retired military personnel worked for different military services and engineers, defense industry specialists.

Even it is a newly founded company, it has more than 120M USD turnover during 2020.

## Table of Content

Cartridge Case Production	:3
Indenting, Stamping, Necking Machine	:4
Trimming Machine	:5
Dimension Control Machine	:6
Mount Annealing Machine	:7
Lead Core Press	:8
Bullet Assembly Press	:9
Priming Machine	:11
Weight Control Machine	:12
Assembling Machine	:13
Varnishing Machine	:14
Visual Check Machine	:15
Packing Machine	:16



## Machine Specifications

<b>Capacity</b>	240 pcs/min
<b>Power Supply</b>	35 kW

Cups are automatically inserted into the fingers on a carry bar at the first stations. Each stroke of the machine advances the cups to first draw, then second draw, then third draw and trimming. The trimmed parts are then ejected.

Its capacity has been doubled with double feeding and double hitting.



MADE IN  
TURKEY



PROMPT  
RESPONSIVE



END PRODUCT  
QUALITY



## Machine Specifications

Capacity	240 pcs/min
Power Supply	35 kW



In this press,

- the mouth of each part is shaped and qualified
- primer pocket and the head are formed
- identification markings are stamped
- head is pierced, mouth of the case is tapered followed by sizing of the mouth to the correct diameter



MADE IN  
TURKEY



PROMPT  
RESPONSIVE



END PRODUCT  
QUALITY



# Trimming Machine

## Machine Specifications

Capacity	120 pcs/min
Power Supply	75 kW



Finish Trimming Machine is an automatic lathe dedicated for trimming and grooving of brass cartridge cases.

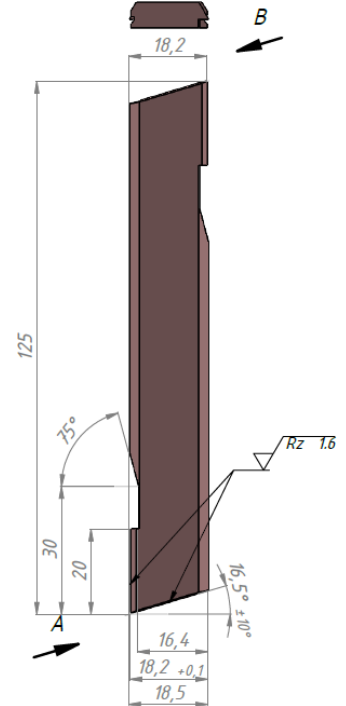
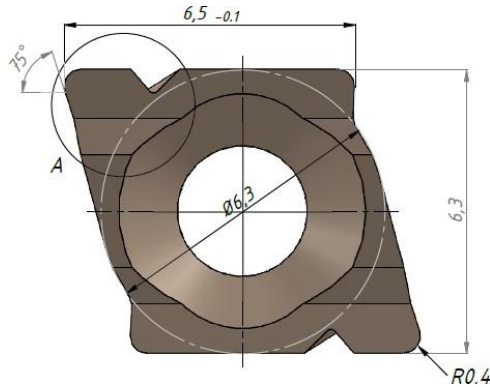

MADE IN  
TURKEY



PROMPT  
RESPONSIVE



END PRODUCT  
QUALITY

## Machine Specifications

<b>Capacity</b>	300 pcs/min
<b>Power Supply</b>	5 kW

### Our Offered

- Camera Gauging System
- Mouth & Primer Vision System
- Image Processing and radial illumination of the casing (Case Vision System)



MADE IN  
TURKEY



PROMPT  
RESPONSIVE



END PRODUCT  
QUALITY



## Machine Specifications

Capacity	240 pcs/min
Power Supply	90 kW

An induction based annealer shall be provided for the mouth annealing for the cases coming out of the head turning and trimming machine.

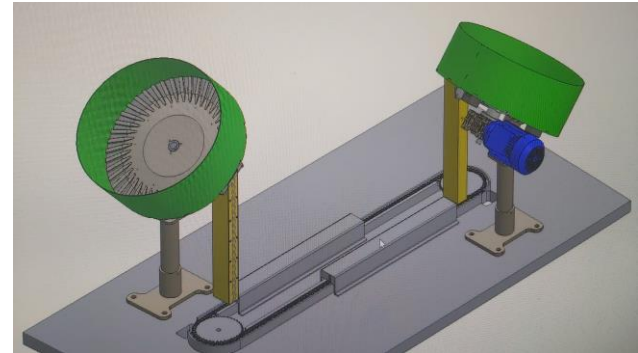
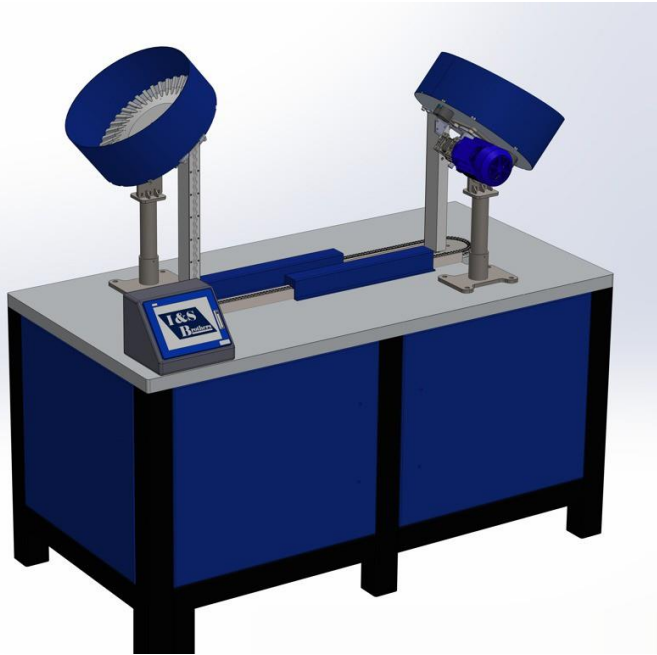

MADE IN  
TURKEY



PROMPT  
RESPONSIVE



END PRODUCT  
QUALITY





# Lead Core Press

## Machine Specifications

Capacity	300 pcs/min
Power Supply	5kW

it is a single station horizontal press that used to shape lead wire into lead cores for the FMJ or plated bullet production. Molds in this specific press could be adjusted according to caliber measures

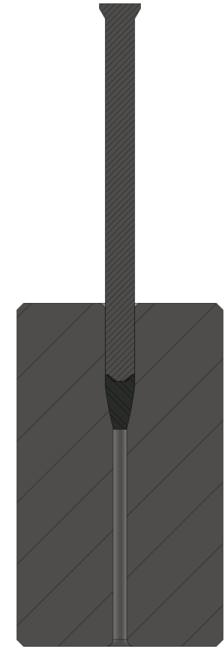
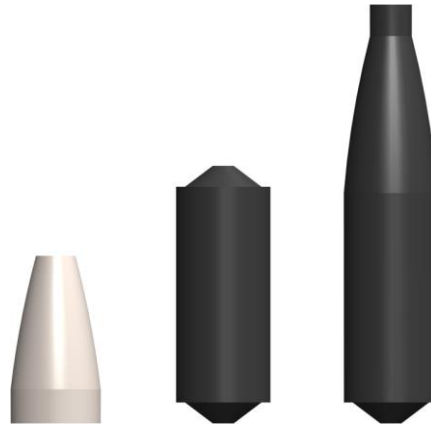
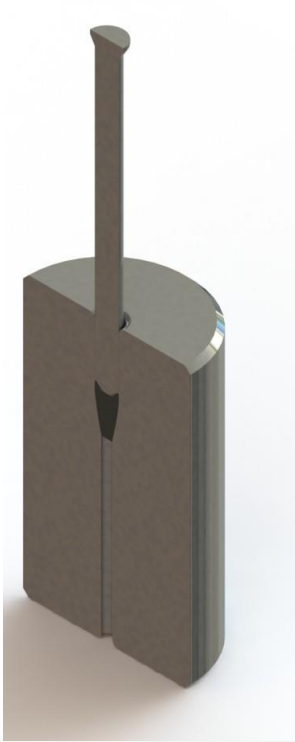

MADE IN  
TURKEY



PROMPT  
RESPONSIVE



END PRODUCT  
QUALITY



# Bullet Assembly Press

## Machine Specifications

Capacity	120 pcs/min
Power Supply	35 kW

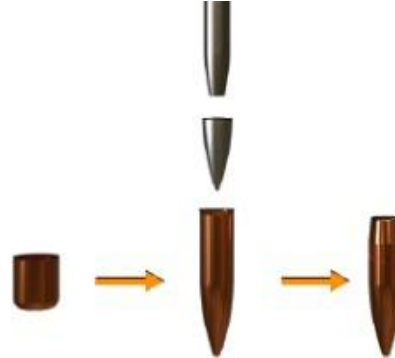

A vertical H type press that assembles FMJ cups, lead cores and other related pieces. Each component transferred from a station to another by grippers mounted on the transfer slide.



MADE IN  
TURKEY



PROMPT  
RESPONSIVE



END PRODUCT  
QUALITY

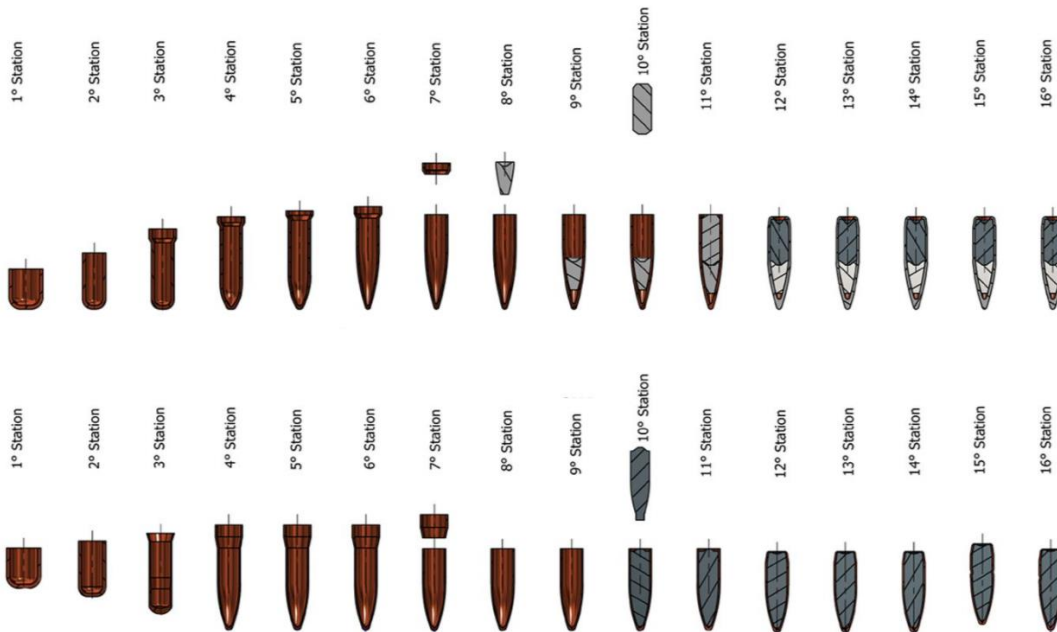

MADE IN  
TURKEY



PROMPT  
RESPONSIVE



END PRODUCT  
QUALITY



## Machine Specifications

Capacity	120 pcs/min
Power Supply	4 kW

This machine is used for inserting primers into cartridge cases. Primers are fed by a vibration bowl and cases are fed by means of a collator. A camera placed on primer chute to detect misoriented primers. Primers are inserted to cases in a continuous way by means of cam driven punches. In the last station primer seams are ringed by a riveting punch.

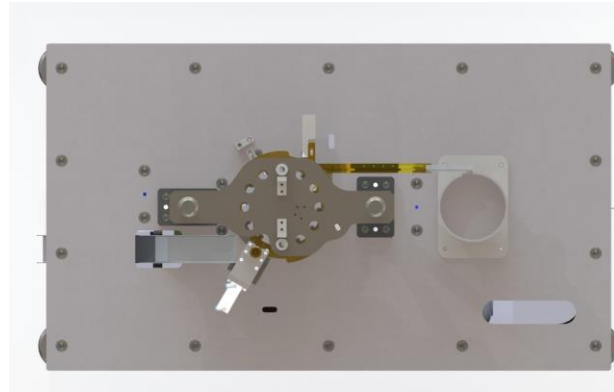

MADE IN  
TURKEY



PROMPT  
RESPONSIVE



END PRODUCT  
QUALITY

## Machine Specifications

Capacity	300 pcs/min
Power Supply	3 kW



The Checkweigher System provides perfect ease of use with its high weighing precision.

- Separates out-of-limit products as under-limit and over-limit
- Works at high speed
- It can be used for case, bullet and cartridges



MADE IN  
TURKEY



PROMPT  
RESPONSIVE



END PRODUCT  
QUALITY



### Machine Specifications

Capacity	120 pcs/min
Power Supply	15 kW

- Mouth Inspection - Faulty cases will be automatically rejected
- Propellant dosing and dispensing
- Propellant level checking with rejection of faulty components
- Bullet insertion
- Bullet seating
- Crimping height and cartridge overall shape inspection with reject of faulty components

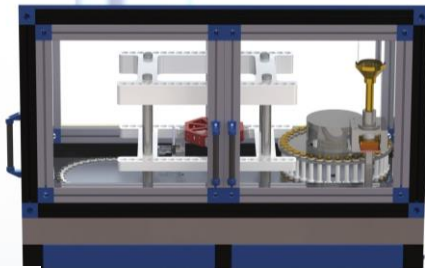

MADE IN  
TURKEY



PROMPT  
RESPONSIVE



END PRODUCT  
QUALITY

## Machine Specifications

<b>Capacity</b>	120 pcs/min
<b>Power Supply</b>	5 kW

Primer seams and case mouths are varnished at the same time in this specific machine. The cases are dried by exposing to the UV light.

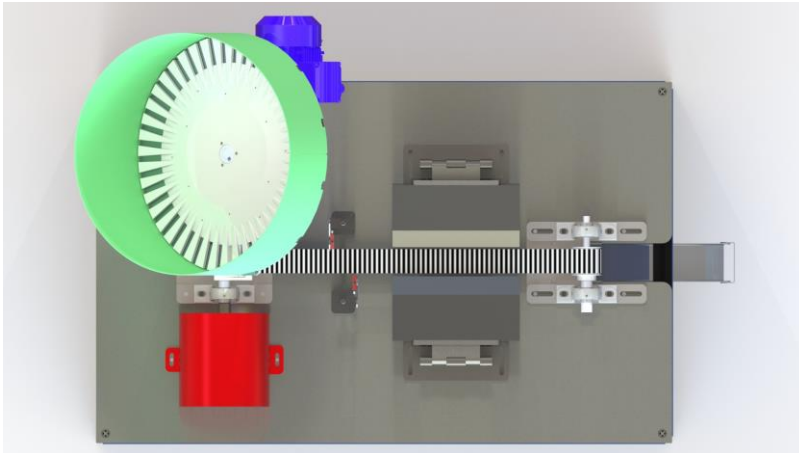

MADE IN  
TURKEY



PROMPT  
RESPONSIVE



END PRODUCT  
QUALITY



## Machine Specifications

Capacity	240 pcs/min
Power Supply	5 kW



Visual inspection machine helps the operators to make certain whether the surface of the ammunition components are conforming to the quality standards in a way that the components are rotated by a chain conveyor so that the operator could inspect through the mirrors and lights that if any imperfections exist.



MADE IN  
TURKEY



PROMPT  
RESPONSIVE



END PRODUCT  
QUALITY



## Machine Specifications

Capacity	200 pcs/min
Power Supply	12 kW

Our packaging machine packs the cartridges as per buyer's requirement into a cardboard/plastic box with or without separators.



MADE IN  
TURKEY



PROMPT  
RESPONSIVE



END PRODUCT  
QUALITY





**I & S**  
**Brothers**

**NP**  
**SAVUNMA**